

V-Link-200 Series

Wireless 8 Channel Analog Input Sensor Node



V-Link-200 Series - versatile, ruggedized, eight-channel analog sensor node with high sample rates and datalogging capability

LORD Sensing LXRS Wireless Sensor Networks enable simultaneous, high-speed sensing and data aggregation from scalable sensor networks. Our wireless sensing systems are ideal for test and measurement, remote monitoring, system performance analysis, and embedded applications.

The gateways are the heart of the LORD Sensing wireless sensing system. They coordinate and maintain wireless transmissions across a network of distributed wireless sensor nodes. Some nodes have integrated sensors, while others are designed with multi-sensor connectivity for application flexibility. The LORD Sensing LXRS wireless communication protocol between LXRS nodes and gateways enable high-speed sampling, ± 50 microseconds node-to-node synchronization, and lossless data throughput under most operating conditions.

Users can easily program nodes for continuous, periodic burst, or event-triggered sampling with the SensorConnect software. The optional web-based SensorCloud interface optimizes data aggregation, analysis, presentation, and alerts for sensor data from remote networks.

Product Highlights

- Four differential input channels, four single-ended analog input channels, and an internal temperature channel.
- Ideal for remote and long-term measurement of Wheatstone bridge and analog-type sensors such as strain, force, pressure, acceleration and vibration.
- Supports continuous sampling at rates up to 4 kHz and periodic burst, event-triggered, and datalogging at sample rates up to 8 KHz.
- Field-replaceable, extended-life battery operation or wide range 7.5-36 V dc external power
- Ruggedized housing (remove with optional IP67 faceplate)
- Bolt-down or DIN-rail mounting

Features and Benefits

High Performance

- Lossless data throughput and node-to-node sampling synchronization of $\pm 50 \mu\text{s}$ in LXRS-enabled modes
- High resolution data with 18-bit A/D converter
- Wireless range up to 1.5 km (500 m typical)

Ease of Use

- Scalable networks for easy expansion
- Rapid deployment with wireless framework
- Remote configuration, acquisition, and display of sensor data with SensorConnect
- Optional web-based SensorCloud platform optimizes data storage, viewing, alerts, and analysis.

Cost Effective

- Reduction of costs associated with wiring
- Low-cost per channel with 8 input channels per node

Applications

- Condition-based monitoring
- Structural load and stress monitoring
- Test and measurement



Specifications

General	
Sensor input channels	Differential analog, 4 channels Single-ended analog, 4 channels
Integrated sensors	Internal temperature, 1 channel
Data storage capacity	16 M Bytes (5+ million data points)
Analog Input Channels	
Selectable measurement ranges	Differential: ± 1.22 mV dc to 156 mV dc Single-ended: ± 2.56 V dc, ± 5.12 V dc, ± 10.24 V dc, 0 to 5.12 V dc, 0 to 10.24 V dc
Single-ended input impedance	1 Mohm
Input bandwidth	DC-4000 Hz (-3 dB cutoff)
ADC Resolution	18 bit
Accuracy	± 0.1 % full scale typical
Noise	± 0.02 % full scale
Temperature stability	< 0.1 % full scale over temperature range
Anti-aliasing filter	Differential Inputs Only: user-set 128 Hz to 4 kHz, Sallen-Key Single-ended Inputs: -3 dB at 15 kHz, Two-pole
Bridge excitation voltage	+4.096 V dc (150 mA max)
Measurement gain and offset	16 to 2048, user-set in software on differential channels
Integrated Temperature Channel	
Measurement range	-40 °C to 85 °C
Accuracy	± 1 °C (at 25 °C) typical
Resolution	0.1 °C
Sampling	
Sampling modes	Synchronized, low duty cycle, datalogging, event-triggered
Sampling rates	Continuous sampling: 1 sample/hour to 4 KHz * Periodic burst sampling: 32 Hz to 8 KHz *
Sample rate stability	± 5 ppm
Network capacity	Up to 127 nodes per RF channel depending on settings. See: http://www.microstrain.com/configure-your-system
Synchronization between nodes	± 50 μ sec
Operating Parameters	
Wireless communication range	Outdoor/line-of-sight: 1.5 km(ideal), 800 m (typical)** Indoor/obstructions: 250 m (typical)**
Radio frequency (RF) transceiver carrier	2.405 to 2.470 GHz spread spectrum over 14 channels, power settings from 4 dBm (2.5 mW) to 16 dBm (39 mW)
Radio frequency (RF) channel allocation	2.40 to 2.483 GHz spread spectrum with 14 distinct channels
RF communication protocol	IEEE 802.15.4, FSK/GMSK
RF transmit power	User-set from 0 dBm to 20 dBm. Power output restricted regionally to operate within legal requirements
RF receive sensitivity	-99.4 dBm
RF transmission rate	250 kbps
Power source	Internal: Four replaceable 3.6 V dc, 2.4 Ah Lithium batteries External: +7.5 to 36.0 V dc
Operating temperature	-40 °C to + 85 °C
Acceleration limit	100 g
Physical Specifications	
Dimensions	129 mm x 82.5 mm x 31 mm
Weight	283 grams (with batteries), 217 grams (without batteries)
Environmental rating	Indoor use (IP67 faceplate available)
Enclosure material	Molded polycarbonate
Integration	
Mounting	Bolt down or DIN-rail mount
Compatible gateways	All WSDA-101 base stations and gateways
Compatible sensors	Differential analog sensors, -10 to +10 V dc analog sensors
Connectors	Screw terminal block (M4 circular connectors on IP67 faceplate)
Shunt calibration	Internal shunt calibration resistor 499 K Ω , differential channels
Software	SensorCloud, SensorConnect, Windows 7 (or newer)
Software development kit (SDK)	Open-source MicroStrain Communications Library (MSCL) with sample code available in C++, Python, and .NET formats http://www.microstrain.com/software/mscl
Regulatory compliance	FCC (U.S.), IC (Canada), MIC (Japan), CE (European Union), ROHS

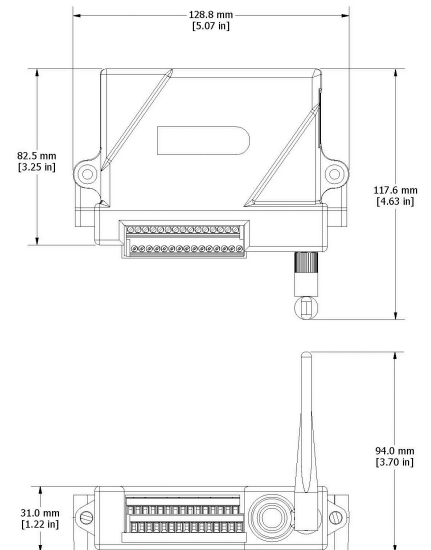
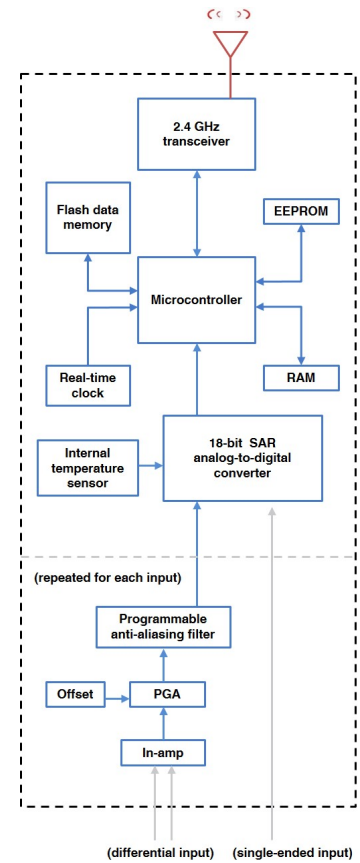

LORD SENSING

LORD Corporation
MicroStrain® Sensing Systems
459 Hurricane Lane, Suite 102
Williston, VT 05495 USA

ph: 802-862-6629
sensing_sales@LORD.com
sensing_support@LORD.com

* Divide maximum rate by number of active channels ** Line of sight with antenna at 3 meters