

Demod-DIGITAL

Displacement Signal Conditioner

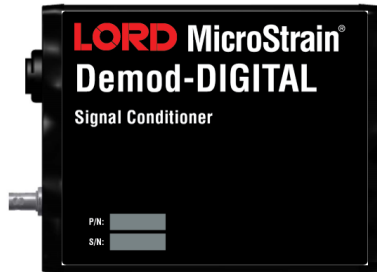

Demod-DIGITAL- high-performance signal conditioner for digital or analog acquisition

LORD Sensing Differential Variable Reluctance Transducer (DVRT[®]) systems enable precise micro-position measurement for a wide variety of applications. From slow, slight movements over time to high frequency vibration, the DVRT system provides accurate, repeatable measurement. Each system consists of a sensor, cable and signal conditioning module calibrated as one unit to ensure accuracy.

The Demod-DIGITAL stores specific calibration values in an internal lookup table and provides a highly accurate displacement output on both digital serial and analog output channels.

NOTE: *Designed for use with LORD Sensing DVRT sensors. With a Demod-DIGITAL purchase, current LORD Sensing customers may return sensors for calibration free of charge.*

Product Highlights

- Internal calibration data delivers unmatched accuracy
- Digital serial and analog outputs
- 10X to 50X more accurate, repeatable signal processing
- Clean, high-level signals to output connections

Features and Benefits

High Performance

- Precision synchronous demodulation
- Calibrated with each sensor for high accuracy outputs
- Line voltage transient filtering and pure sine wave excitation source to the sensor bridge

Ease of Use

- No conversion needed for digital output.
- Compatible with LORD Sensing SensorConnect™ software
- Factory-set output filtering and calibration-model options
- Rapid warm-up time
- Complete solution - no other system integration required

Applications

- Linear and angular position measurements
- Strain, deflection and deformation measurements
- Dimensional gauging

DISPLACEMENT SENSORS



SIGNAL CONDITIONERS

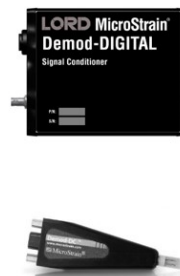

Digital



Analog

Analog



OUTPUT



Specifications

General	
Sensor input channels	Single channel, inductive DVRT
Sensor Input Channel	
Demodulation	Synchronous, DC output
Sensor excitation	AC Sine Wave, 140 kHz typical
Analog Output	
Analog output voltage	0 to 10 V dc (standard), 0 to 5 V dc (optional)
Output gain	Adjustable from 14 to 10,000 (factory set during calibration)
Analog low pass filter	Two-pole, active Butterworth, -3 dB at 800 Hz (standard), factory adjustable 10 Hz to 20 kHz
Digital Output	
Format	RS232 (RS485 upon request)
Data	Timestamp, Displacement (mm)
Operating Parameters	
Power source	12 V dc nominal ± 1 V dc (universal voltage wall AC/DC converter provided)
Power consumption	70 mA typical
Power indicator	Multi-color status indicator
Operating temperature	-20 °C to +60 °C
Device warm-up time	5 minutes recommended
Physical Specifications	
Dimensions	70 mm x 95 mm x 20 mm
Weight	113 grams
Enclosure material	Black anodized aluminum
Mounting	Desktop with rubber feet
Integration	
Connectors	Center-positive DC barrel socket (power supply); 4 pin M8 receptacle (sensor input); HDBNC (analog output); Micro-DB9
Sensor cable	4-pin receptacle to 4-pin mini, calibrated with sensor and signal conditioner
Compatible sensors	LORD Sensing DVRT sensors
Software	SensorConnect™ and SensorCloud™
Regulatory compliance	CE, ROHS

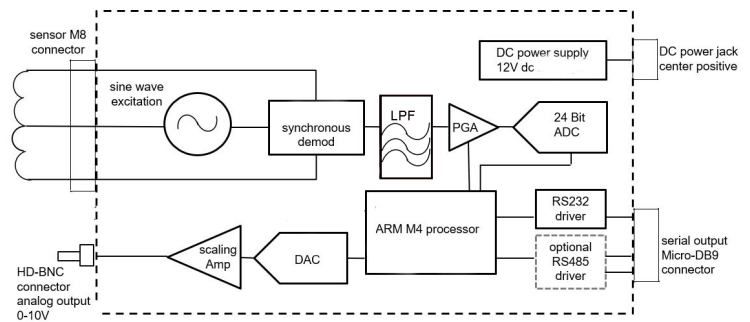
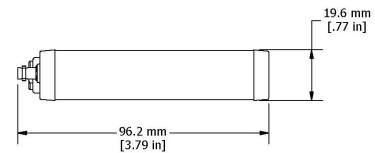
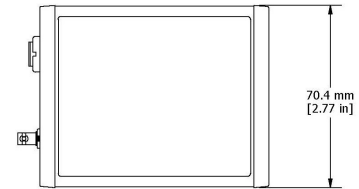

LORD SENSING

ph: 802-862-6629

sensing_sales@LORD.com

sensing_support@LORD.com