

2

1

REVISION HISTORY				
REV	AUTHOR	DESCRIPTION	DATE	APPROVED

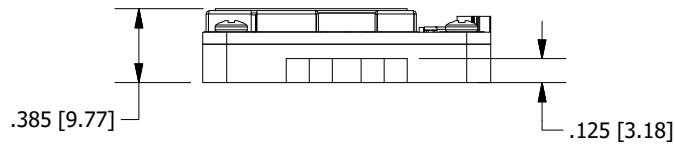
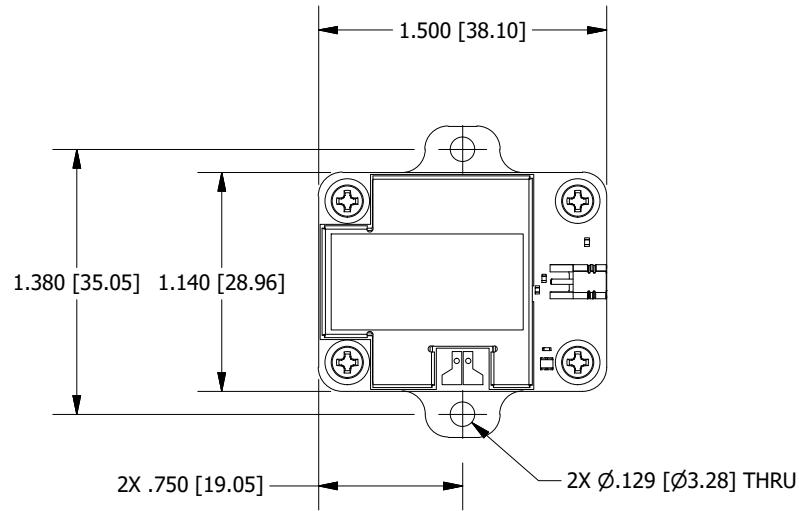

NOTES:
1.) DRAWING SCALE 1:1

UNLESS OTHERWISE SPECIFIED
ALL DIMENSIONS ARE IN INCHES.
TOLERANCES:(UOS):
.X = ± .02
.XX = ± .01
.XXX = ± .005
HOLE DIAMETERS: ± .002
ANGLES: ± 0.5°
SURFACE FINISH: 63
MICROINCHES
MATERIAL:

DRAWN chad thelen	2/21/2018
REFERENCE PLM SYSTEM FOR APPROVALS	
THIS DRAWING AND SPECIFICATIONS ARE THE PROPERTY OF LORD-MICROTRAIN AND SHALL NOT BE PRODUCED WITHOUT PERMISSION FROM LORD-MICROTRAIN	

L O R D Sensing 459 HURRICANE LN. WILLISTON VT 802-862-6629	
TITLE G-LINK-200-OEM W/BASE	
DWG NO 6306-1031	REV -
CAGE CODE OXYZ9	WWW.MICROTRAIN.COM
SIZE: A	SHEET 1 OF 1

2

1