

2



1

REVISION HISTORY				
REV	AUTHOR	DESCRIPTION	DATE	APPROVED

B

B

ACCEL IS LOCATED ON THE UNDERSIDE OF THE BOARD

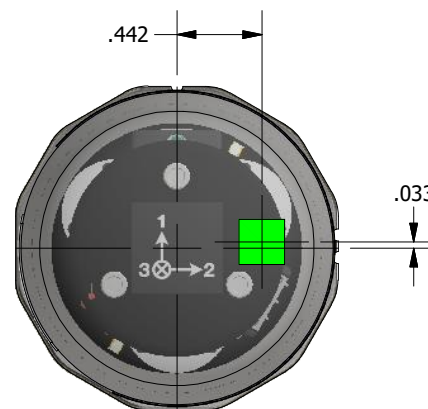
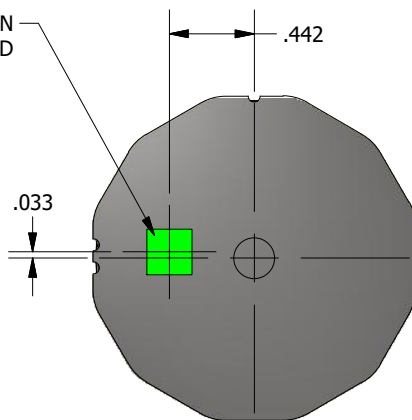

A

A

NOTES:
1.) DRAWING SCALE 1:1

UNLESS OTHERWISE SPECIFIED
ALL DIMENSIONS ARE IN INCHES.
TOLERANCES:(UOS):
.X = ± .02
.XX = ± .01
.XXX = ± .005
HOLE DIAMETERS: ± .002
ANGLES: ± 0.5°
SURFACE FINISH: 63
MICROINCHES
MATERIAL:

DRAWN
thomas leamon 10/3/2016

REFERENCE PLM SYSTEM
FOR APPROVALS

THIS DRAWING AND SPECIFICATIONS ARE THE PROPERTY OF
LORD-MICROTRAIN AND SHALL NOT BE PRODUCED WITHOUT
PERMISSION FROM LORD-MICROTRAIN

L O R D Sensing

459 HURRICANE LN. WILLISTON VT 802-862-6629

TITLE
G-Link-200 Accel Location

DWG NO
G-Link-200 Accel Location

REV
-

CAGE CODE
OXYZ9

SIZE: A SHEET 1 OF 1 WWW.MICROTRAIN.COM

2



1