

# LORD USER MANUAL

## MV5-ML5 Sensors -- CANopen Communications

Compact, Ruggedized Attitude Reference and Inertial Measurement Units



**LORD** SENSING  
MicroStrain



LORD® Sensing  
459 Hurricane Lane Suite 102  
Williston, VT 05495  
United States of America

Phone: 802-862-6629

[www.microstrain.com](http://www.microstrain.com)  
[sensing\\_support@LORD.com](mailto:sensing_support@LORD.com)  
[sensing\\_sales@LORD.com](mailto:sensing_sales@LORD.com)

Copyright © 2019 LORD Corporation

3DM®, 3DM-DH®, 3DM-DH3™, 3DM-GX1®, 3DM-GX2®, 3DM-GX3®, 3DM-GX4-15™, 3DM-GX4-25™, 3DM-GX4-45™, 3DM-GX4™, 3DM-RQ1™, 3DM-GQ4™, AIFP®, Ask Us How™, Bolt-Link®, DEMOD-DC®, DVRT®, DVRT-Link™, EH-Link®, EmbedSense®, ENV-Link™, FAS-A®, G-Link®, G-Link2™, HS-Link®, IEPE-Link™, Inertia-Link®, Little Sensors, Big Ideas.®, Live Connect™, LXRS®, MathEngine®, MicroStrain®, MVEH™, MXRS®, Node Commander®, PVEH™, RHT-Link®, RTD-Link™, SensorCloud™, SG-Link®, Shock-Link™, Strain Wizard®, TC-Link®, Torque-Link™, V-Link®, Watt-Link™, Wireless Simplicity, Hardwired Reliability™, and WSDA® are trademarks of LORD Corporation.

Document 8500-0097 Revision C

Subject to change without notice.

## Table of Contents

<b>1. Sensor Overview</b>	5
<b>2. Installation</b>	6
Installation	6
Sensor Calibration	6
Temperature Calibration	6
Cabling and Termination	7
Pinout	7
Dimensions	8
<b>3. MV5-AR Technical Data</b>	10
IMU Accelerometer specifications	10
IMU Gyroscope Specifications	10
Attitude (pitch and roll) Output Specifications	11
System Interface	11
Power Supply	11
Environmental	12
EMC & Electrical Compliance Standards	12
Physical Characteristics	13
<b>4. ML5-AR Technical Data</b>	14
IMU Accelerometer Specifications	14
IMU Gyroscope Specifications	14
Attitude (pitch and roll) Output Specifications	15
System Interface	15
Power Supply	16
Environmental	16
EMC and Electrical Compliance Standards	17
Physical Specifications	17

## Table of Contents

<b>5. CANopen Communication</b> .....	18
Process Data Objects and Electronic Data Sheets.....	18
TPDO Mapping .....	19
Layer Setting Services .....	19
Data Quantities .....	20
Standardized Device Profile (CiA 410).....	20
<b>Manufacturer Specific Profile</b> .....	21
Euler Angle Data Quantities.....	21
Quaternion Data Quantities.....	21
Angular Rate (Gyroscope) Data Quantities.....	22
Accelerometer Data Quantities .....	22
<b>Device Information</b> .....	23
Storing Device Parameters .....	23
Device Configuration.....	23
PDO Data Period .....	23
Filter Bandwidth .....	23
Tare Orientation .....	24
Sensor to Vehicle Rotation.....	25
Reset Attitude .....	25
Data output mode control.....	25
<b>6.Support</b> .....	26
General Instructions.....	26
Warranty Repairs .....	26
Technical support.....	26
Sales Support.....	27
<b>Safety Notice</b> .....	27

## 1. Sensor Overview

The LORD Sensing M Series brings a new level of precision to measurements of dynamic inclination, acceleration, and angular rate in challenging environments such as those encountered in heavy-duty construction, off-highway, agriculture, and trucking industries.

The M-Series sensors provide a choice of units for your CAN equipped application. Select the MV5-AR for the most demanding environments, or the ML5-AR, with slightly reduced specifications, in more cost sensitive applications. Both units are rugged, high-performance devices.

Both the MV5-AR and ML5-AR utilize the power of a sophisticated Auto-Adaptive Extended Kalman Filter (EKF) to remove errors associated with vibration, sudden linear motions, and quake, resulting in a true reading of inclination under all conditions. The wide bandwidth, low noise accelerometer and 1000dps gyroscope allow accurate IMU measurements of the most extreme events, making it ideal for monitoring shock and vibration fatigue.

LORD Sensing's state-of-the-art temperature compensation and calibration assures error-free performance over the full operational temperature range.

The compact size, wide 4.5 to 36 V power range, IP68 / IP69K rating, and **CAN J1939 or CANopen communications interface options** make the MV5-AR and ML5-AR a single part solution for a full range of vehicle sizes and applications. **You must specify communications protocol at time of order.**



If you are not yet using CAN communications, or if you are considering your first sensor, we recommend you consult with LORD Sensing sales. We offer a wide range of sensors with a choice of serial communications options.

## 2. Installation

### 2.1 Installation

The sensor has three mounting holes for fastening with M8 (5/16") socket head cap screws, (hardware not included). The sensor can be mounted in any orientation, as required for the application. The axes are labeled on the face of the sensor for reference. When mounting requires the device to be rotated with respect to the vehicle or implement reference frame, the slope outputs may be adjusted into optimum measurement range using the device configuration commands in section 5. Note that rotation about the X axis is roll, and rotation about the Y axis is pitch.

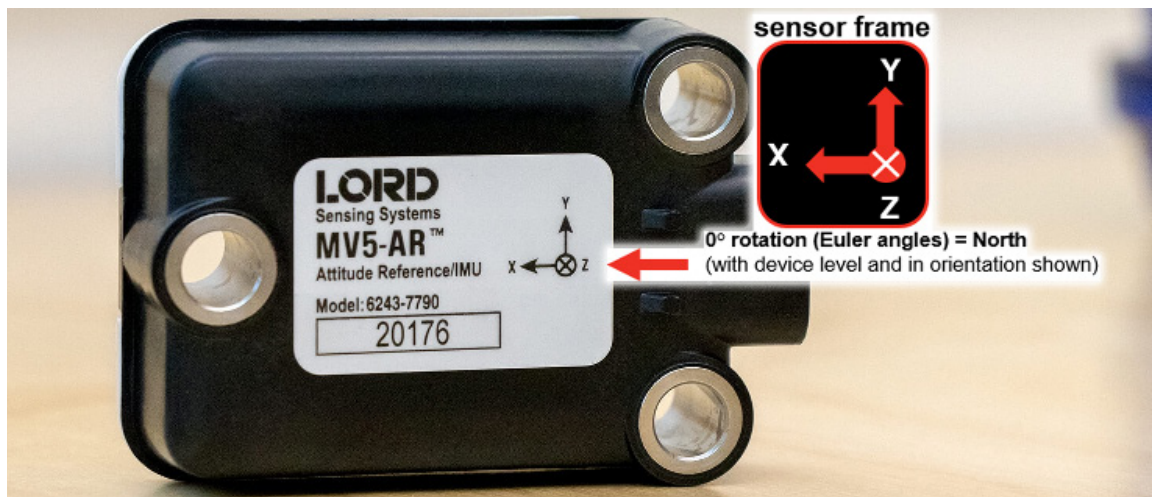

### 2.2 Sensor Calibration

All internal sensors in the M-Series are calibrated when the device is manufactured. Exposure to conditions beyond the operating specifications may cause permanent changes to the sensor characteristics and render the calibration ineffective. For example, if the sensor has been exposed to excessive shock beyond the rated g-force, performance may be compromised. Indications of internal sensor damage may be observed as excessive measurement offsets or drift when the sensor is in a neutral motionless position.

### 2.3 Temperature Calibration

All sensor conversion and calibration formulas include temperature compensation. All computed outputs and IMU sensor outputs are automatically adjusted for local temperature.

## 2.4 Cabling and Termination

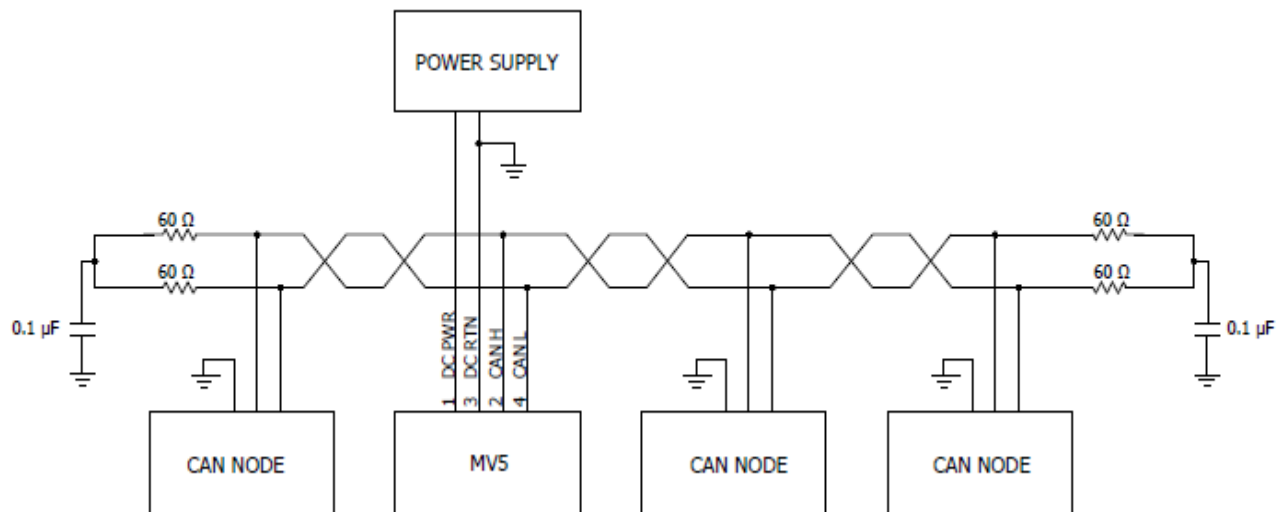

LORD recommends [split termination](#) on both ends of the cable for optimum EMC performance.

Recommended mating connector shell: TE Connectivity 776487-1 or equivalent

## 2.5 Pinout

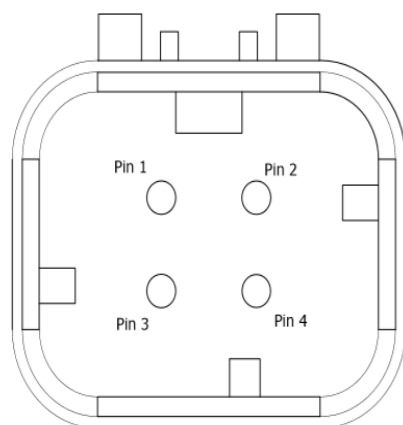

### Connector Termination

Pin	Description
1	DC Power
2	CAN High
3	DC Return
4	CAN Low

**Mating connector: AMPSEAL 16 Series gold plated 4 pin**  
**(available for purchase, contact sales.)**

## 2.6 Dimensions

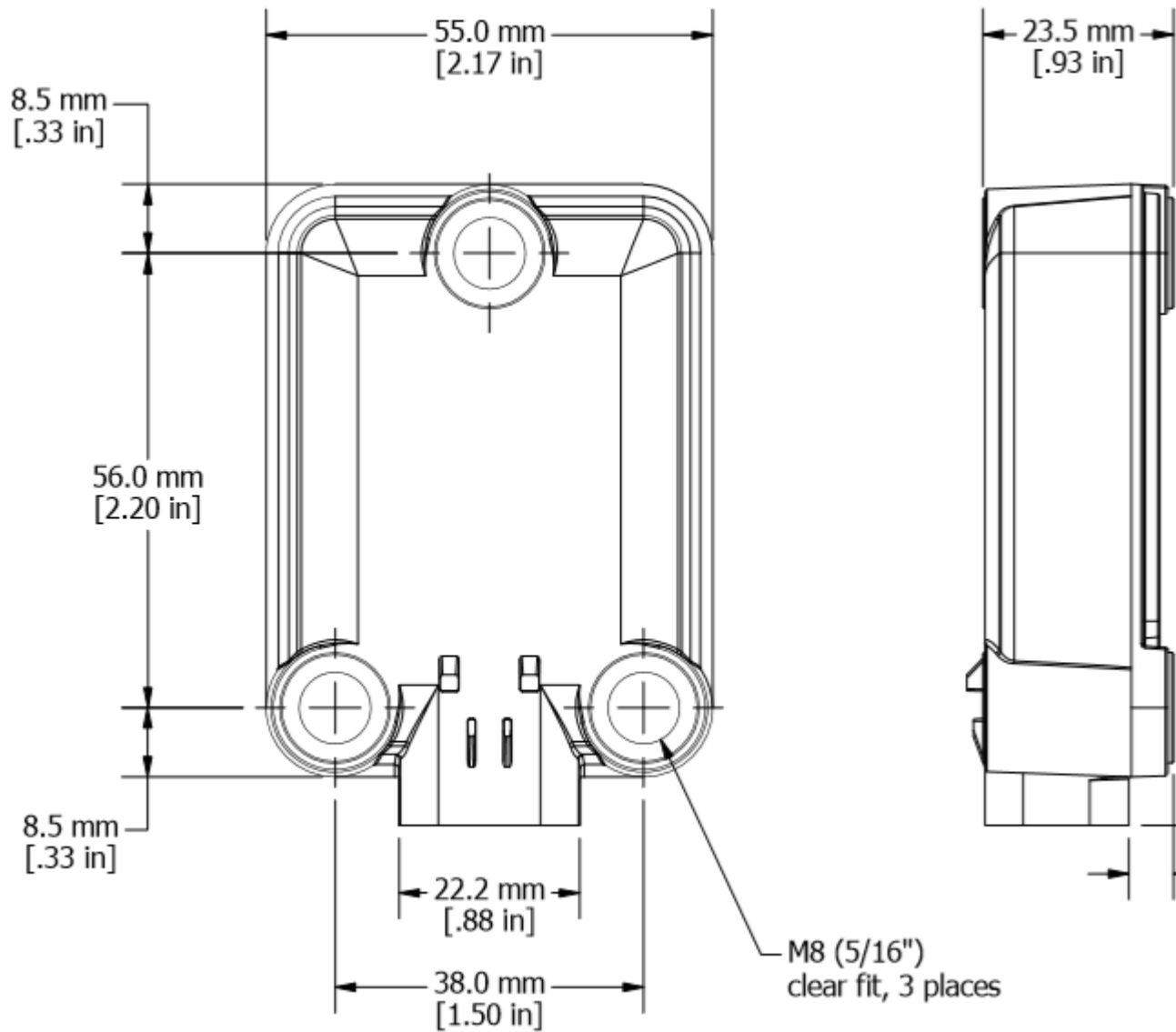



## 2.7 Connecting with CAN

For clients needing CAN connectivity from their computers, LORD Sensing can suggest two ways to begin.

Clients with existing CAN networks who wish to verify communications with a specific sensor may find this unit, from Peak-System GmbH useful. It comes complete with communications monitor software, PCAN-View. Full details and ordering information can be found at: [peak-system.com/PCAN-USB](http://peak-system.com/PCAN-USB).



An alternative, and somewhat less expensive interface is manufactured by Lawicel-AB, in south Sweden. The CANUSB interface is a small dongle which provides instant CAN connectivity. It can be treated by software as a virtual COM port, with the FTDI USB drivers. Sample programs in C, C++, C#, VB6, Delphi and Linux can be found on their downloads page: [http://www.can232.com/?page\\_id=75](http://www.can232.com/?page_id=75).

For your convenience, the CANUSB device can be purchased directly from LORD Sensing. ([sensing\\_sales@LORD.com](mailto:sensing_sales@LORD.com)). Or, you can obtain it directly from Lawicel ([CANUSB.com](http://CANUSB.com)) where you will find a listing of their international distributors.

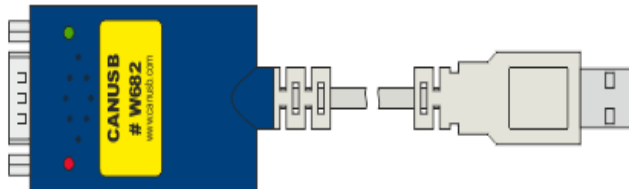

## 3. MV5-AR Technical Data

### 3.1 IMU Accelerometer Specifications (3 Axis)

Characteristic	Min.	Typ.	Max.	Unit
Measurement range	-20		+20	g
Accel output range	-320		+320	m/s <sup>2</sup>
Non-linearity	-0.04		+0.04	% fs
Resolution		0.05		mg
Bias instability	-0.08		+0.08	mg
Initial bias error	-0.004		+0.004	g
Scale factor stability	-0.05		+0.05	%
Noise density		85		$\mu\text{g}/\sqrt{\text{Hz}}$
Alignment error	-0.05		+0.05	%
Bandwidth	1	40	225	Hz
Offset error over temperature		0.2		%
Gain error over temperature		0.05		%
Scale factor non-linearity (@ 25°C)		0.04	0.2	%
IMU data output rate	1	100	500	Hz

### 3.2 IMU Gyroscope Specifications (3 Axis)

Characteristic	Min.	Typ.	Max.	Unit
Measurement range	-1000		+1000	°/sec
Gyro output range	-250		+250	
Non-linearity	-0.06		+0.06	% fs
Resolution		<0.003		°/sec
Bias instability		8		°/hr
Initial bias error	-0.1		+0.1	°/sec
Scale factor stability	-0.05		+0.05	%
Noise density		0.0075		°/sec $\sqrt{\text{Hz}}$
Alignment error	-0.05		+0.05	%
Bandwidth	1	40	500	Hz
Offset error over temperature		0.1		%
Gain error over temperature		0.1	0.4	%
Scale factor non-linearity (@ 25°C)		0.04	0.15	%

### 3.3 Attitude (pitch and roll) Output Specifications

Characteristic	Min.	Typ.	Max.	Unit
Accuracy		±0.2		rms deg
Calculation update rate		500		Hz
Slope Output range	-90	-	+90	deg
Measurement range (2 axis)	-180	-	+180	deg
Resolution		0.05		deg
Static Inclination Error (-40°C to 85°C)		±0.2°		deg
Translational acceleration error		±0.44°		deg
Settling time		5	200	mSec
Repeatability		0.5		deg
Max Data output rate	1	100	500	Hz

### 3.4 System Interface

Characteristic	Parameter
Communication	CAN 250 kb/s
Protocol	CANopen
Connector	AMPSEAL 16 receptacle, 4 Pin gold plated pins
CANH/CANL Operating Common-Mode Range	-7V to +12V
CANH/CANL Absolute Maximum Rating	±36V
Short Circuit Protection	All pins, automatic restart
Start-up time: IMU	1 second
Start-up time: Slope (EKF)	5 seconds

### 3.5 Power Supply

Characteristic	Min.	Nominal	Max.
Operating Supply Voltage Range	4.5V	5V (regulated), or 12V or 24V (vehicle power)	36V
Power consumption (all voltages)		625mW	
Reverse Voltage Limits	<b>-60V absolute max steady-state</b> -15mA max clamped steady-state current if exceeding -60V -15.5A max clamped brief surge current if exceeding -60V		
Overvoltage Limits	<b>+40V absolute max steady-state</b> +50mA max clamped steady-state current if exceeding +40V +114A max clamped brief surge current if exceeding +40V		

### 3.6 Environmental

Characteristic	Parameter
Operating temperature	-40°C to +85°C
Storage temperature	-40°C to +125°C
Vibration (Random)	MIL-STD-202G, Method 214A ,Test Condition 1-B, 24 hrs/axis
Vibration (Sweep)	J1455 Appendix A 10-2000Hz, 10 g Peak, 10hr/octave/axis
Ingress protection	IP68 (Immersion), IP69K (Pressure Wash)
Thermal shock	SAE J1455 10X
Salt spray	MIL-STD-202G, Method 101E Condition A (96 hours)
Hot dunk	5X, 30 mins @ 85C, 30 mins @ ice bath, operating
UV	Stabilized Polymer
Mechanical shock (Drop)	1m on to concrete surface 3x, J1455
Mechanical shock (Operating)	50g, 11ms 1/2sine, 3X direction, 18 total, MIL STD 202, M213

### 3.7 EMC & Electrical Compliance Standards

Characteristic	Standard	Test Levels
Radiated Immunity: ALSE	ISO 11452-5:2004	200 V/m 200 MHz to 3.2 GHz
Radiated Immunity: Bulk Current Injection	ISO 11452-5:2002	200mA 1 to 400 MHz
Radiated Immunity: Strip line	ISO 11452-5:2002	200mA 10 kHz to 400 MHz
Radiated emissions	CISPR 25 ED. 4.0: 2016	150 kHz to 2.5 GHz, Class 3 and 5
Conducted emissions	CISPR 25 ED. 4.0: 2016	150 kHz to 88 MHz, Class 5
Mutual coupling	ISO 7637-2: 2011 Section 5.6.3	Pulses 3a and 3b
ESD direct contact discharge	ISO 10605	8kV
ESD air discharge	ISO 10605	15KV
Superimposed AC Voltage	ISO 16750-2: 2010, Section 4.4	12V, 4Vp-p 24V, 10V p-p
Starting Profile	ISO 16750-2: 2010	12V, Table3, I-IV 24V, Table 4, I-III
Inducted EM Noise on Signal lines	ISO 7637-3:2016	CCC/ICC/DCC methods

### 3.8 Physical Specifications

Characteristic	Parameter
Dimensions	L 78.9 mm x W 55.0 mm x H 23.5 mm
Weight	110.5 grams
Enclosure material	PBT Thermoplastic, Reinforced
Ingress protection	IP68, IP69K
MTBF	826,440 hrs Telcordia SR332 (issue 3)
Mounting	3 x M8 (5/16") (user supplied) Installation torque 20 ±2 Nm (14.75 ± 1.5 lb-ft)
Regulatory compliance	RoHS, REACH, CE

## 4. ML5-AR Technical Data

### 4.1 IMU Accelerometer Specifications (3 Axis)

Characteristic	Min.	Typ.	Max.	Unit
Measurement range	-8		+8	g
Accel output range	-320		+320	m/s <sup>2</sup>
Non-linearity	-0.08		+0.08	% fs
Resolution		0.05		mg
Bias instability	-0.08		+0.08	mg
Initial bias error	-0.008		+0.008	g
Scale factor stability	-0.08		+0.08	%
Noise density		120		$\mu\text{g}/\sqrt{\text{Hz}}$
Alignment error	-0.1		+0.1	%
Bandwidth	1	40	225	Hz
Offset error over temperature		0.2		%
Gain error over temperature		0.05		%
Scale factor non-linearity (@ 25°C)		0.1	0.2	%
IMU data output rate	1	100	100	Hz

### 4.2 IMU Gyroscope Specifications (3 Axis)

Characteristic	Min.	Typ.	Max.	Unit
Measurement range	-1000		+1000	°/sec
Gyro output range	-250		+250	
Non-linearity	-0.06		+0.06	% fs
Resolution		<0.003		°/sec
Bias instability		8		°/hr
Initial bias error	-0.1		+0.1	°/sec
Scale factor stability	-0.05		+0.05	%
Noise density		0.0075		°/sec $\sqrt{\text{Hz}}$
Alignment error	-0.05		+0.05	%
Bandwidth	1	40	500	Hz
Offset error over temperature		0.1		%
Gain error over temperature		0.1	0.4	%
Scale factor non-linearity (@ 25°C)		0.04	0.15	%
IMU data output rate	1	100	100	Hz

### 4.3 Attitude (pitch and roll) Output Specifications

Characteristic	Min.	Typ.	Max.	Unit
Accuracy		±0.5		rms deg
Calculation update rate		100		Hz
Slope Output range	-85	-	+85	deg
Measurement range (2 axis)	-180	-	+180	deg
Resolution		0.05		deg
Static Inclination Error (-40°C to 85°C)				deg
Translational acceleration error				deg
Settling time		5	200	mSec
Repeatability		0.5		deg
Data output rate	1	100	100	Hz

### 4.4 System Interface

Characteristic	Parameter
Communication	CAN 250 kb/s
Protocol	CANopen
Connector	AMPSEAL 16 receptacle, 4 pin, gold plated pins
CANH/CANL Operating Common-Mode Range	-7V to +12V
CANH/CANL Absolute Maximum Rating	±36V
Short Circuit Protection	All pins, automatic restart
Start-up time: IMU	1 second
Start-up time: Slope (EKF)	5 seconds

#### 4.5 Power Supply

Characteristic	Min.	Nominal	Max.
Operating Supply Voltage Range	4.5V	5V (regulated), or 12V or 24V (vehicle power)	36V
Power consumption (all voltages)		250 mW nominal	
Reverse Voltage Limits	<b>-60V absolute max steady-state</b> -15mA max clamped steady-state current if exceeding -60V -15.5A max clamped brief surge current if exceeding -60V		
Overtoltage Limits	<b>+40V absolute max steady-state</b> +50mA max clamped steady-state current if exceeding +40V +114A max clamped brief surge current if exceeding +40V		

#### 4.6 Environmental

Characteristic	Parameter
Operating temperature	-40°C to +85°C
Storage temperature	-40°C to +125°C
Vibration (Random)	MIL-STD-202G, Method 214A, Test Condition 1-B, 24 hrs/axis
Vibration (Sweep)	J1455 Appendix A 10-2000Hz, 10 g Peak, 10hr/octave/axis
Ingress protection	IP68 (Immersion), IP69K (Pressure Wash)
Thermal shock	SAE J1455 10X
Salt spray	MIL-STD-202G, Method 101E Condition A (96 hours)
Hot dunk	5X, 30 mins @ 85C, 30 mins @ ice bath, operating
UV rating	stabilized
Mechanical shock (Drop)	1m on to concrete surface 3x, J1455
Mechanical shock (Operating)	50g, 11ms 1/2sine, 3X direction, 18 total, MIL STD 202, M213



#### 4.7 EMC and Electrical Compliance Standards

Characteristic	Standard	Test Levels
Radiated Immunity: ALSE	ISO 11452-5:2004	200 V/m 200 MHz to 3.2 GHz
Radiated Immunity: Bulk Current Injection	ISO 11452-5:2002	200mA 1 to 400 MHz
Radiated Immunity: Strip line	ISO 11452-5:2002	200mA 10 kHz to 400 MHz
Radiated emissions	CISPR 25 ED. 4.0: 2016	150 kHz to 2.5 GHz, Class 3 and 5
Conducted emissions	CISPR 25 ED. 4.0: 2016	150 kHz to 88 MHz, Class 5
Mutual coupling	ISO 7637-2: 2011 Section 5.6.3	Pulses 3a and 3b
ESD direct contact discharge	ISO 10605	8kV
ESD air discharge	ISO 10605	15KV
Superimposed AC Voltage	ISO 16750-2: 2010, Section 4.4	12V, 4Vp-p 24V, 10V p-p
Starting Profile	ISO 16750-2: 2010	12V, Table3, I-IV 24V, Table 4, I-III
Induced EM Noise on Signal lines	ISO 7637-3:2016	CCC/ICC/DCC methods

#### 4.8 Physical Specifications

Characteristic	Parameter
Dimensions	L 78.9 mm x W 55.0 mm x H 23.5 mm
Weight	110.5 grams
Enclosure material	PBT Thermoplastic, Reinforced
Ingress protection	IP68, IP69K
MTBF	826,440 hrs; Telcordia SR332 (issue 3)
Mounting	3 x M8 (5/16") (user supplied) Installation torque 20 ±2 Nm (14.75 ± 1.5 lb-ft)
Regulatory compliance	RoHS, REACH, CE

## 5. CAN Messages and Communication

Data supplied by the M-Series Sensors are communicated through CANopen communications interface. To learn more about CANopen communication standards, go to the CAN in Automation (CiA) website.

Throughout this document, CANopen Object Dictionary entries will be denoted by their index and sub-index. An example of this form is: [0x1018\_01], where 0x1018 is the index and 01 denotes the sub-index of this entry.

The M-Series sensors are compliant with both CiA 301: CANopen Application Layer and Communication Profile, and CiA 410: Device Profile for Inclinometer.

### 5.1 Process Data Objects and Electronic Data Sheets (EDS)

Electronic data sheets can be found for each TPDO1 configuration on the LORD Microstrain website.

The M-Series sensor outputs process data via Transmit PDOs 1-3. Table 5.2.1 summarizes the TPDO assignments and mapping

## 5.2 TPDO Mapping

TPDO mappings are outlined. All mapped values are unsigned 16-bit integers. Different scale factors apply to different types of quantities. See the tables in section 7 for more information on each data quantity.

5.2.1 TPDO Mapping				
<b>Description</b>	TPDO mappings are outlined. All mapped values are unsigned 16-bit integers. Different scale factors apply to different types of quantities. See the table in section 7 for more information on each data quantity.			
<b>TPDO1</b>	[0x6010_00] Slope Long	[0x6020_00] Slope Lateral		
<b>TPDO2</b>	[0x5E10_01] Gyroscope-X	[0x5E10_02] Gyroscope-Y	[0x5E10_03] Gyroscope-Z	[0x5E10_04] Figure of Merit
<b>TPDO3</b>	[0x5E00_01] Accleration-X	[0x5E00_02] Accleration-Y	[0x5E00_03] Accleration-Z	[0x5E00_04] Figure of Merit

## 5.3 Layer Setting Services

Layer Setting Services (LSS) is a protocol in CANOpen that defines a means for nodes to have network operating parameters configured in the field. Under Standard LSS, unconfigured nodes may be configured by an LSS Master, one node at a time. This process can be lengthy if there is more than one unconfigured LSS node in a network. LSS Fastscan is an augmented LSS scan cycle that attempts to rapidly identify and configure unconfigured LSS slaves. The M-Series sensors support both Standard LSS and LSS Fastscan. Additionally it is possible to alter the baud rate of the M-Series Sensors using LSS.

## 5.4 Data Quantities

The MV5-AR supports multiple simultaneous streaming channels via TPDO transfer. This section describes the various quantities that are available.

### 5.4.1 Standardized Device Profile (CiA 410)

5.4.1 CiA 410 Inclinometer Data Quantities			
Description	This table outlines the data quantities described in CiA 410 Device Profile for Inclinometers		
Parameter Index and Name	Data Type	Access Permissions	Notes
[0x6000] Resolution	Unsigned16	Read/Write	See CiA 410 for valid values
[0x6010] Slope Long16	Integer16	Read Only	See CiA 410
[0x6011] Slope Long16 Operating Parameter	Unsigned8	Read Only	
[0x6012] Slope Long16 Preset Value	Integer16	Read Only	
[0x6013] Slope Long16 Offset	Integer16	Read Only	
[0x6014] Slope Long16 Differential Offset	Integer16	Read Only	
[0x6010] Slope Lateral16	Integer16	Read Only	See CiA 410
[0x6011] Slope Lateral16 Operating Parameter	Unsigned8	Read Only	
[0x6012] Slope Lateral16 Preset Value	Integer16	Read Only	
[0x6013] Slope Lateral16 Offset	Integer16	Read Only	
[0x6014] Slope Lateral16 Differential Offset	Integer16	Read Only	

## 5.5 Manufacturer Specific Profile

5.5.1 Euler Angle Data Quantities [0x5E00]			
Description	This table outlines the acceleration data quantities.		
Parameter Index and Name	Data Type	Access Permissions	Notes
[0x5E20_01] Euler Angle – Pitch	Integer16	Read Only	0.05°/LSB
[0x5E20_02] Euler Angle – Roll	Integer16	Read Only	0.05°/LSB
[0x5E20_03] Euler Angle – Yaw	Integer16	Read Only	0.05°/LSB

5.5.2 Quaternion Data Quantities [0x5E40]			
Description	This table outlines the acceleration data quantities.		
Parameter Index and Name	Data Type	Access Permissions	Notes
[0x5E40_01] Quaternion - q0	Integer16	Read Only	1/32768 per LSB
[0x5E40_02] Quaternion - q1	Integer16	Read Only	1/32768 per LSB
[0x5E40_03] Quaternion - q2	Integer16	Read Only	1/32768 per LSB
[0x5E40_04] Quaternion -q3	Integer16	Read Only	1/32768 per LSB
[0x5E40_04] Quaternion - Figure of Merit	Unsigned8	Read Only	0=Quaternion Channel Functional 1= Degraded 2=error 3=Not Available

### 5.5.3 Angular Rate (Gyroscope) Data Quantities

Description	This table outlines the angular rate (gyroscope) data quantities.		
Parameter Index and Name	Data Type	Access Permissions	Notes
[0x5E10_01] Gyroscope – X	Integer16	Read Only	0.05°/s/LSB
[0x5E10_02] Gyroscope – Y	Integer16	Read Only	0.05°/s/LSB
[0x5E10_03] Gyroscope – Z	Integer16	Read Only	0.05°/s/LSB
[0x5E10_04] Gyroscope – Figure of Merit	Unsigned8	Read Only	0 = Gyroscope Channels Functional 1 = Degraded 2 = Error 3 = Not Available

### 5.5.4 Accelerometer Data Quantities [0x5E00]

Description	This table outlines the acceleration data quantities.		
Parameter Index and Name	Data Type	Access Permissions	Notes
[0x5E00_01] Acceleration – X	Integer16	Read Only	1mG/LSB
[0x5E00_02] Acceleration – Y	Integer16	Read Only	1mG/LSB
[0x5E00_03] Acceleration – Z	Integer16	Read Only	1mG/LSB
[0x5E00_04] Acceleration – Figure of Merit	Unsigned8	Read Only	0 = Acceleration Channels Functional 1 = Degraded 2 = Error 3 = Not Available

## 5.6 Device Information

Device information is stored in the standard Object Dictionary index 0x1018. This entry contains all relevant identity information.

## 5.7 Storing Device Parameters

The M-Series sensors support standard CANopen parameter storage. If desired, applied settings may be stored using the objects under index 0x1010.

## 5.8 Device Configuration

Device settings for the M-Series sensor reside under Object Dictionary entry [0x2100]. They may be read from and written to via SDO. When a setting is written, it is immediately applied. If there is an issue with the parameter being written, an appropriate SDO abort code will be triggered.

Note that applying a setting utilizes non-volatile memory which has a finite durability of 32,000,000 settings changes. Writing the same value to a setting does not use up a write cycle. This should be considered when programming the device.

5.8.1 PDO Data Period [0x2100_01], [0x2100_02], [0x2100_03]				
<b>Description</b>	These sub-indexes control the PDO transmission period of the corresponding data channels. Valid values: 0 = disable data channel, 2-500			
<b>Parameter Index and Name</b>	<b>Data Type</b>	<b>Default</b>	<b>Unit</b>	<b>Notes</b>
[0x2100_01] TPDO1 Data Rate	Unsigned16	100	ms	Controls TPDO1
[0x2100_02] TPDO2 Data Rate	Unsigned16	0	ms	Controls TPDO2
[0x2100_03] TPDO3 Data Rate	Unsigned16	0	ms	Controls TPDO3

5.8.2 Filter Bandwidth [0x2100_05], [0x2100_06]				
<b>Description</b>	These sub-indexes control the filter bandwidth of the accelerometer and gyroscope. Valid values: 1-250, 0xFFFF = use default (40 Hz)			
<b>Parameter Index and Name</b>	<b>Data Type</b>	<b>Default</b>	<b>Unit</b>	<b>Notes</b>
[0x2100_05] Accelerometer Filter Bandwidth	Unsigned16	40	Hz	
[0x2100_06] Gyroscope Filter Bandwidth	Unsigned16	40	Hz	

### 5.8.3 Tare Orientation [0x2100\_08]

<b>Description</b>	<p>Writing to this address tares the sensor so the current orientation is treated as the reference. The pitch and roll granularity parameters cause the sensor to round its absolute orientation to the nearest multiple of the granularity before applying a tare translation.</p> <p>For example, if the sensor is mounted with a +47° absolute pitch and a tare command is issued with a 5° pitch granularity, the sensor will apply a -45° rotation transform on the pitch axis, and the resulting angle reported on the pitch axis will be 2°.</p> <p>With a granularity of 0°, an exact-angle tare will be performed.</p> <p>The yaw orientation is treated as an offset value to the current absolute yaw. A full rotational range allows sensors mounted with different orientations to have their yaw axes aligned in the vehicle reference frame.</p> <p>Object Dictionary index [0x2100_08] is defined as an Unsigned32 data type that is further broken into three segments. Each segment should be treated as an unsigned integral value of the byte length defined in the table. The definition of each segment is included in this table.</p> <p>This index is write-only.</p>						
	<b>Bit Field</b>	<b>Byte Offset</b>	<b>Length</b>	<b>Resolution</b>	<b>Value Offset</b>	<b>Range</b>	<b>Default Values</b>
	<b>Roll Granularity</b>	1	1 Bytes	1° per bit	0	0 to 90°	0°
	<b>Pitch Granularity</b>	2	1 Bytes	1° per bit	0	0 to 90°	0°
<b>Yaw Direction</b>	3	2 Bytes	.1° per bit	0	0 to 360°	0°	



### 5.8.4 Sensor to Vehicle Rotation [0x2100\_09]

<b>Description</b>	The output of the device is rotated so that when the sensor is at the reference position (0° on all axes), the actual output corresponds to the rotation angles stored at this index. This can be used to adjust the sensor's mounting orientation with respect to the vehicle or component orientation. For example, if the sensor is mounted +90° on the Y axis when the vehicle is actually at 0°, set the Y rotation below to -90°. That will result in the sensor outputting 0° when the vehicle is at 0° rather than outputting 90°.					
	Object Dictionary index [0x2100_09] is defined as an Unsigned48 data type that is further broken into three 16-bit segments. Each segment should be interpreted as an Unsigned16. The definition of each segment is included in this table.					
	Writing 0xFFFF for any segment will restore that segment to its default setting.					
	This setting is absolute. Writing a value to this field overwrites any previous transformations including tare.					
<b>Bit Field</b>	<b>Byte Offset</b>	<b>Length</b>	<b>Resolution</b>	<b>Value Offset</b>	<b>Range</b>	<b>Default Values</b>
<b>X Rotation</b>	1	2 Bytes	.1° per bit	-180°	-180° to +180°	0°
<b>Y Rotation</b>	3	2 Bytes	.1° per bit	-180°	-180° to +180°	0°
<b>Z Rotation</b>	5	2 Bytes	.1° per bit	-180°	-180° to +180°	

### 5.8.5 Reset Attitude [0x2100\_0A]

<b>Description</b>	Writing a 0xFF to this Object Dictionary index will reset the EKF in the MV5-AR. The attitude will be unavailable for a short time until the filter finishes initializing. This command is useful in the case of a sensor over-range event	
<b>Bit field</b>	<b>Byte Offset</b>	<b>Required Value</b>
<b>Reset Entry</b>	1	0xFF

### 5.8.6 Data Output Mode Control [0x2100\_0B]

<b>Description</b>	This Object Dictionary controls the output data mode of Transmit PDO 1. After updating this value, it is necessary to store the parameter using the store parameters service under object index 0x1010				
<b>Output Mode Value</b>	<b>Channel Configuration</b>	<b>TPDO 1 Mapping</b>			
<b>0</b>	CiA 410 Inclinometer	Slope Long 16 (0x6010)		Slope Lateral 16 [0x6010]	
<b>1</b>	Euler Angles	Pitch [0x5E00_01]	Roll [0x5E00_02]	Yaw [0x5E00_03]	Figure of Merit [0x5E00_04]
<b>2</b>	Quaternion	q0 [0x5E40_01]	q1 [0x5E40_01]	q2 [0x5E40_+01]	q3 [0x5E40_01]

## 6. Support

### 6.1 Repair and Calibration

#### General Instructions

For assistance, please contact LORD Sensing Sales or Technical Support to obtain a Return Merchandise Authorization (RMA) number. Returned merchandise must be in the original packaging, including manuals, accessories, cables, etc. with the RMA number clearly printed on the outside of the package. Removable batteries should be removed and packaged in separate protective wrapping. Please include the LORD Sensing model number and serial number, as well as your name, organization, shipping address, telephone number, and email. Normal turnaround for RMA items is seven days from receipt of item by LORD Sensing.

#### Warranty Repairs

LORD Sensing warrants its products to be free from defective material and workmanship for a period of one (1) year from the original date of purchase. LORD Sensing will repair or replace, at its discretion, a defective product if returned to LORD Sensing within the warranty period. This warranty does not extend to any LORD Sensing products that have been subject to misuse, alteration, neglect, accident, incorrect wiring, mis-programming, or use in violation of operating instructions furnished by LORD Sensing. It also does not extend to any units altered or repaired for warranty defect by anyone other than LORD Sensing.

#### Non-Warranty Repairs

All non-warranty repairs/replacements include a minimum charge. If the repair/replacement charge exceeds the minimum, LORD Sensing will contact the customer for approval to proceed beyond the minimum with the repair/replacement.

### 6.2 Technical Support

There are many resources for product support found on the LORD Sensing website including technical notes, FAQs, and product manuals.

<https://www.microstrain.com/contact-support>

<https://www.microstrain.com/inertial/mv5-ar>

<https://www.microstrain.com/inertial/ml5-ar>

For further assistance our technical support engineers are available to help with technical and applications questions.

**Technical Support** [sensing\\_support@LORD.com](mailto:sensing_support@LORD.com)

**Phone:** 802-862-6629

Live Chat is available from the website during business hours: 8:00 AM to 5:00 PM (Eastern

### 6.3 Sales Support

For further assistance, our sales team is available to help with product selection, ordering options, and questions.

**Sales Support** [sensing\\_sales@LORD.com](mailto:sensing_sales@LORD.com)

**Phone:** 802-862-6629

8:00 AM to 5:00 PM (Eastern Time US & Canada)

<http://www.microstrain.com/inertial>

### 6.4 Safety



## WARNING

### PERSONAL INJURY

DO NOT USE these products as safety or emergency stop devices or in any other application where failure of the product could result in personal injury.

**Failure to comply with these instructions could result in death or serious injury.**



## WARNING

### IMPROPER INSTALLATION

Consult with local safety agencies and their requirements when designing a machine-control link, interface, and all control elements that affect safety.

Strictly adhere to all installation instructions.

**Failure to comply with these instructions could result in death or serious injury.**