

MV5-AR

Compact, Ruggedized, CAN bus Attitude Reference and IMU



The LORD Sensing MV5-AR gyro-stabilized inclinometer delivers precision measurements of dynamic inclination, acceleration, and angular rate in challenging environments such as those encountered by heavy-duty construction, off-highway, agriculture, and trucking industries.

The MV5-AR utilizes the power of a sophisticated Auto-Adaptive Extended Kalman Filter (EKF) to remove errors associated with vibration, sudden linear motions, and quake, resulting in a true reading of inclination under all conditions.

LORD Sensing's state-of-the-art temperature compensation and calibration assures error-free performance over the full operational temperature range.

The compact size, wide 4.5 to 36 V power range, IP68/IP69K rating, and CAN J1939 or CANopen communications protocol make the MV5-AR a single part solution for a full range of vehicle sizes and applications.

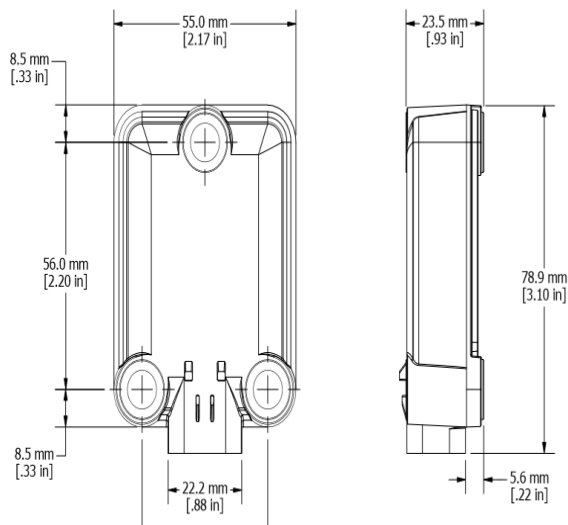

HIGH PERFORMANCE SENSING

- 6 DOF gyro-stabilized inclinometer
- Full accuracy over the entire operational temperature range of -40°C to 85°C
- Auto-Adaptive EKF provides superior dynamic accuracy
- Based on LORD Sensing's proven 5th generation industrial/aerospace solid-state MEMS technology

RUGGEDIZED FOR OFF-HIGHWAY USE

- Compact and rugged reinforced PBT housing is fully sealed for immersion, pressure wash (IP68/IP69K)
- Low-cost, rugged, reliable AMPSEAL 16 connector
- Optional metal guard plate protects sensor and connector and allows connector insertion and removal

FLEXIBLE DEPLOYMENT OPTIONS

- CAN J1939 or CANopen communication
- Simple sensor to vehicle alignment, install in any orientation.
- Wide power input range (4.5Vdc-36Vdc)
- User-settable parameters

APPLICATIONS

- Auto-steer and terrain compensation
- Dynamic incline detection (roll, pitch, rotation)
- Vehicle stability and leveling
- Platform control, alignment and stabilization
- Bucket/Stick/Boom angle
- Impact detection
- Operator feedback
- Precision navigation



Best in Class Inertial Measurement

MV5-AR Ruggedized CAN bus Attitude Reference and IMU

Specifications

General		
Integrated Sensors	Triaxial accelerometer, triaxial gyroscope	
Data Outputs	Pitch, Roll, Angular rate, Acceleration	
Inertial Measurement Unit (IMU) Sensor Outputs		
	Accelerometer	Gyroscope
Measurement range	±20 g	±1000° /sec
Output Range	±320 m/s ²	±250 °/sec
Non-linearity	±0.04% fs	±0.06% fs
Resolution *	0.05 mg	<0.003° /sec
Bias instability	±0.08 mg	8° /hr
Initial bias error	±0.004 g	±0.1° /sec
Scale factor stability	±0.05%	±0.05%
Noise density	85 µg/√Hz	0.0075° /sec/√Hz
Alignment error	±0.05%	±0.05%
Bandwidth	40 Hz	40 Hz
Offset error over temperature	0.2% (typ)	0.1% (typ)
Gain error over temperature	0.05% (typ)	0.1% (typ) 0.4% (max)
Scale factor non-linearity (@ 25°C)	0.04% (typ) 0.2% (max)	0.04% (typ) 0.15% (max)
IMU data output rate	100 Hz (1 Hz to 500 Hz selectable)	
Attitude (pitch and Roll) Outputs		
Accuracy	±0.2° RMS roll and pitch	
EKF update rate	500 Hz	
Pitch	±90°	
Roll	±180°	
Resolution *	0.05°	
Repeatability	0.2°	
Max Data output rate	500 Hz (selectable 1-500, 100 Hz default)	

Physical and Environmental Specifications	
Dimensions	L 78.9 mm x W 55.0 mm x H 23.5 mm
Weight	110.5 grams
Power source	+4.5 V Min, 12/24 V Nominal, +36 V Max
Power consumption	625 mW Nominal
Operating temperature	-40°C to +85°C
Enclosure material	PBT Thermoplastic, Reinforced
Ingress protection	IP68 (Immersion), IP69K (Pressure Wash)
Vibration (random)	MIL-STD-202G, Method 214A, Test Condition 1-B, 24 hrs/axis
Vibration (sweep)	SAE J1455 Appendix A 10-2000Hz, 10 g Peak, 10hr/octave/axis
Thermal shock	SAE J1455 10x
Salt spray	MIL-STD-202G, Method 101E Condition A (96 hours)
Hot dunk	5X, 30 mins @ 85C, 30 mins @ ice bath, operating
Mechanical shock drop	SAE J1455 4.11.3.1; 1m onto concrete surface
Mechanical shock operating	MIL STD 202, M213B; 50g, 11ms 1/2sine, 3x each axis; 18 total,
MTBF	826,440 hrs; Telcordia SR332 (issue 3)
Connectors	AMPSEAL 16 gold plated 4 pin, 4 Position, gold plated pins
Mounting	3 x M8, installation torque 20 Nm ±2 Nm
Regulatory compliance	ROHS, REACH, CE
Communication options	
J1939	Order p/n 6243-7790
CANopen	Order p/n 6243-7792
CAN 250 kb/s standard, custom baud rates available. Consult sales	

* NOTE: Communications protocol may impose resolution limits beyond those of the measuring device. Refer to product manual for details.



LORD Sensing MicroStrain
459 Hurricane Lane Suite 102
Williston, VT 05495 • USA
www.microstrain.com

Customer Support Center (in United States & Canada)
Tel: +1.802.862.6629
Email: sensing_sales@LORD.com | sensing_support@LORD.com
For a listing of our worldwide locations, visit LORD.com

LORD SENSING
MicroStrain