

LORD QUICK START GUIDE

SG-Link[®]-200 Wireless Analog Input Node

The SG-Link[®]-200 is a 3-channel wireless sensor with a rugged, weatherproof enclosure. It includes onboard PGA, filtering, and a high-resolution ADC for precise measurement of a large range of sensor types including strain gauges, load cells, pressure transducers, and accelerometers. The SG-Link-200 is ideal for both test and measurement and long term condition monitoring applications.

Use this document to deploy the SG-Link-200 for data collection. This includes electrical wiring, mounting the device, and using SensorConnect software to configure the node, start sampling, and display data.

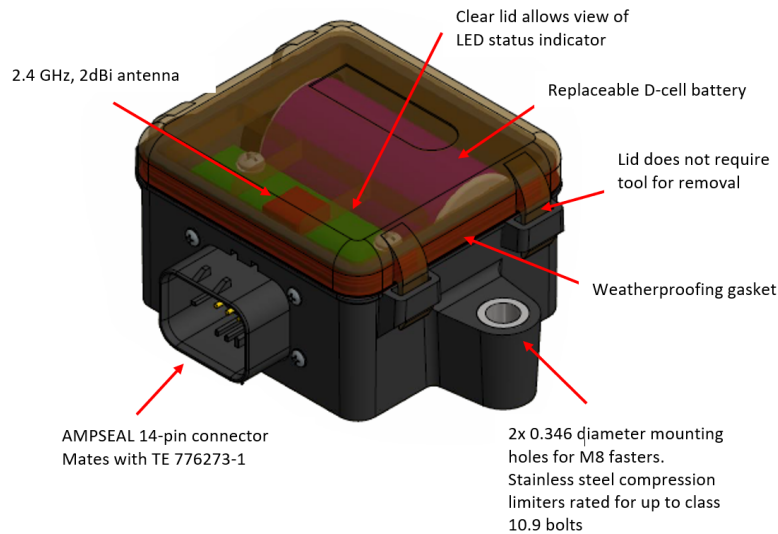

Figure 1. SG-Link[®]-200

Indicator	Behavior	Node Status
Device status indicator	OFF	Node is OFF
	Rapid green flashing on start-up	Node is booting up
	1 (slow) green pulse per second	Node is idle and waiting for a command
	1 green blink every 2 seconds	Node is sampling
	Blue LED during sampling	Node is resynchronizing
	Red LED	Built-in test error

Table 1. Indicator Behaviors

1. Pinout and Sensor Wiring

Pin #	Name	Description	Pin Type	Range	Optional Cable
1	VIN	External supply voltage	Power input	4.0 to 36 V	Red
2	GND	Ground	Power return	GND	Black
3	SP	Sensor Excitation Voltage On continuously or duty cycle to the sensor to save power	Analog Output	1.5V/2.5V (100 mA)	White
4	SP	Sensor Excitation Voltage On continuously or duty cycle to the sensor to save power	Analog Output	1.5V/2.5V (100 mA)	White
5	SP	Sensor Excitation Voltage On continuously or duty cycle to the sensor to save power	Analog Output	1.5V/2.5V (100 mA)	White
6	S3+	Channel 3 Sensor Input + (Full-bridge only)	Analog Input	0 to 2.5 V	Purple
7	S2-	Channel 2 Sensor Input -	Analog Input	0 to 2.5 V	White, yellow stripe
8	GND	Sensor Ground	GND	GND	White, green stripe
9	S1+	Channel 1 Sensor Input + (Full-bridge only)	Analog Input	0 to 2.5 V	Blue
10	S3-	Channel 3 Sensor Input -	Analog Input	0 to 2.5 V	White, purple stripe
11	GND	Sensor Ground	GND	GND	White, green stripe
12	S2+	Channel 2 Sensor Input + (Full-bridge only)	Analog Input	0 to 2.5 V	Yellow
13	S1-	Channel 1 Sensor Input -	Analog Input	0 to 2.5 V	White, blue stripe
14	GND	Sensor Ground	GND	GND	White, green stripe

Table 2. SG-Link-200 Full and Half-Bridge Pinout Descriptions with Optional Cable Colors

Pin #	Name	Description	Pin Type	Range
1	VIN	External supply voltage	Power input	4.0 to 36 V
2	GND	Ground	Power return	GND
3	NC	No Connect	--	--
4	NC	No Connect	--	--
5	NC	No Connect	--	--
6	S3+	Channel 3 Three-wire excitation. Sensor excitation for three wire configuration of quarter bridge strain gauges. Short to S3- when using two-wire configuration.	Analog Output	0 to 2.5 V
7	S2-	Channel 2 Sensor Input	Analog Input	0 to 2.5 V
8	GND	Sensor Ground	GND	GND
9	S1+	Channel 1 Three-wire excitation. Sensor excitation for three wire configuration of quarter bridge strain gauges. Short to S1- when using two-wire configuration.	Analog Output	0 to 2.5 V
10	S3-	Channel 3 Sensor Input	Analog Input	0 to 2.5 V
11	GND	Sensor Ground	GND	GND
12	S2+	Channel 2 Three-wire excitation. Sensor excitation for three wire configuration of quarter bridge strain gauges. Short to S2- when using two-wire configuration.	Analog Output	0 to 2.5 V
13	S1-	Channel 1 Sensor Input	Analog Input	0 to 2.5 V
14	GND	Sensor Ground	GND	GND

Table 3. SG-Link-200 Quarter-Bridge Pinout Descriptions

Figures 2 through 5 illustrate Full-Bridge (Standard), Half-Bridge, Two Wire Quarter-Bridge, and Three Wire Quarter-Bridge wiring.

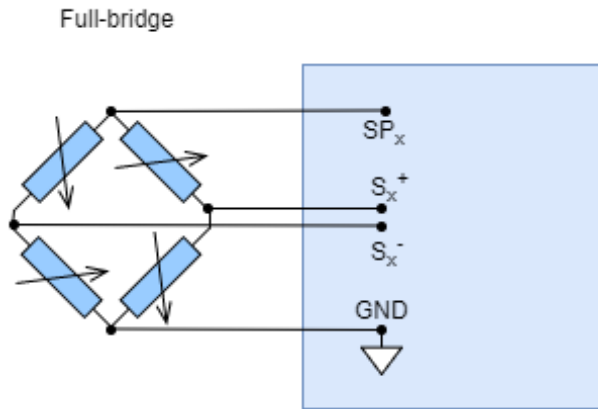

Figure 2. Full-Bridge (Standard)

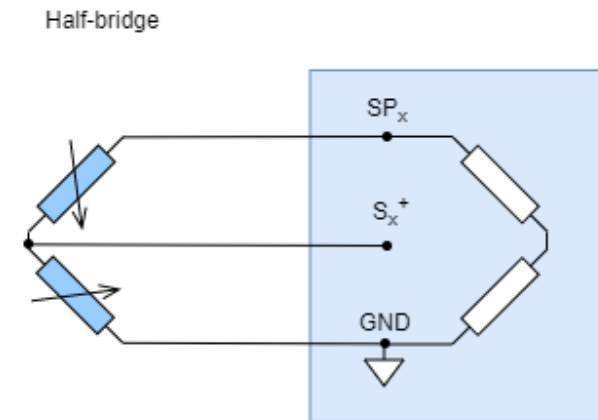

Figure 3. Half-Bridge*

Quarter-bridge, 2-wire

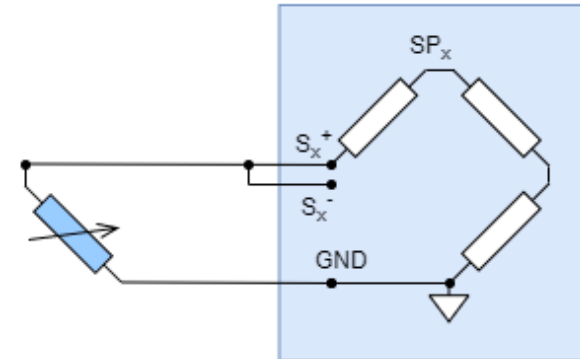

Figure 4. Two Wire Quarter-Bridge*

Quarter-bridge, 3-wire

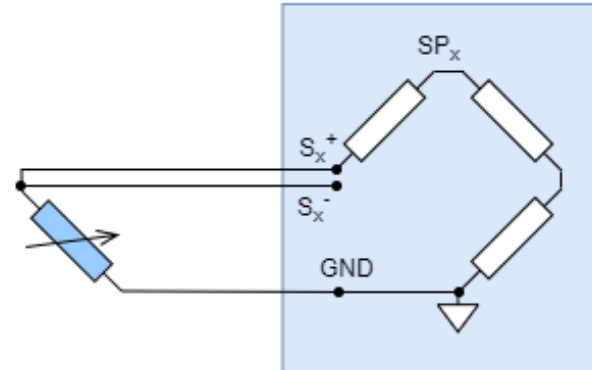

Figure 5. Three Wire Quarter-Bridge*

* Requires optional on-board bridge completion

2. Mounting Recommendations

The SG-Link-200 may be mounted using the holes sized for M8 fasteners. Stainless steel compression limiters are rated for up to class 10.9 bolts. Recommended installation torque is 20 Nm ± 2Nm.

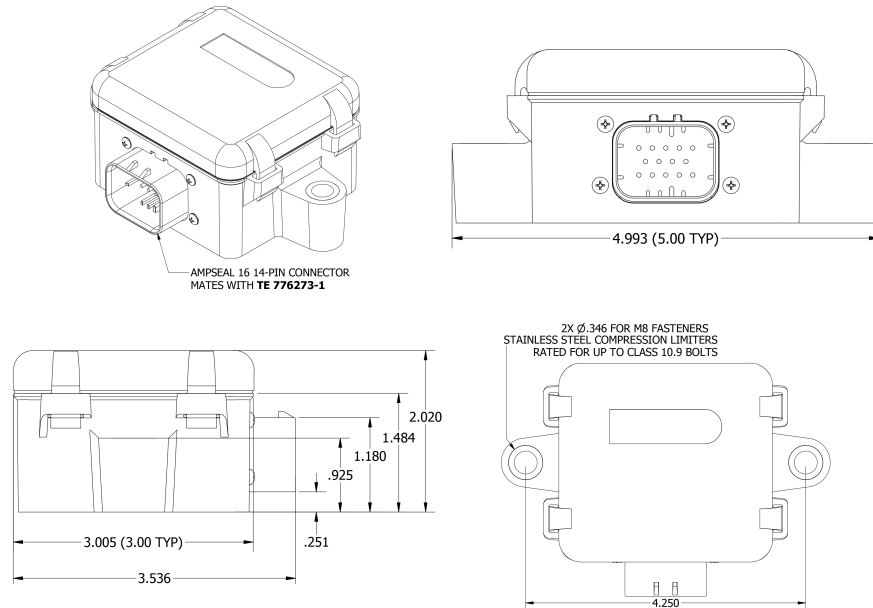

Figure 6. Mounting Dimensions

3. Node Operational Modes

Sensor nodes have three operational modes: active, sleep, and idle. When sampling, the node is in active mode. When sampling stops, the node switches into idle mode, which is used for configuring node settings and allows toggling between active and sleep mode. The node will automatically enter into sleep mode after a user-determined period of inactivity. The node will not enter into sleep mode while active.

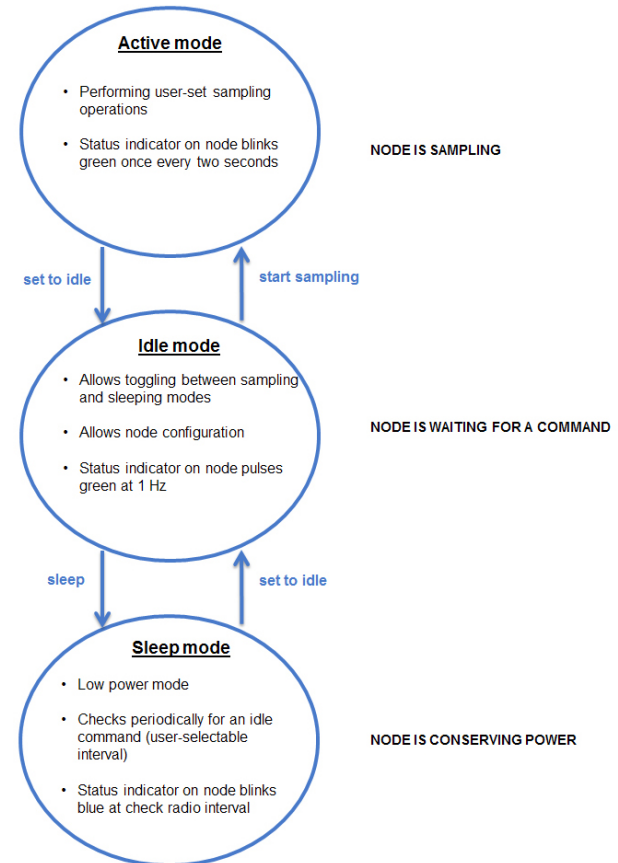

Figure 7. Node Operational Modes

4. Install Software

Install the SensorConnect software on the host computer before connecting hardware. Access the free software download on the LORD Sensing website.



<http://www.microstrain.com/software>

5. Establish Gateway Communication

Drivers for the USB gateways are included in the SensorConnect software installation. With the software installed, the USB gateway will detect automatically whenever the gateway is plugged in.

1. Power is applied to the gateway through the USB connection. Verify the gateway status indicator is illuminated, showing the gateway is connected and powered on.
2. Open the SensorConnect™ software.

The gateway should appear in the Controller window with a communication port assignment. If the gateway is not discovered, verify the port is active on the host computer, then remove and re-insert the USB connector.

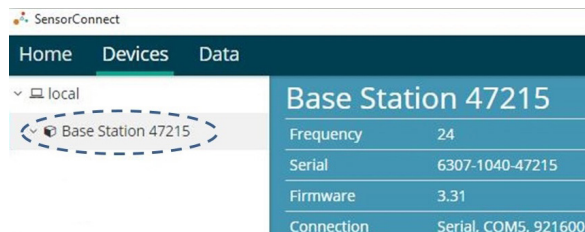

Figure 8. USB Gateway Communication

6. Connect to Nodes

Several methods can be used in SensorConnect to establish communication with the nodes: the automatic node discovery on the same frequency, automatic node discovery on a different frequency, and add node manually.

A. Automatic Node Discovery on Same Frequency

If the base and node are on the same operating frequency, the node will populate below the Base Station listing when powering on the RTD-Link-200.



Figure 9. Node Discovered On Same Frequency

B. Automatic Node Discovery on Different Frequency

If a red circle with a number appears next to the Base Station, the node may be operating on a separate radio channel. Select the Base Station and then select the Nodes on Other Frequencies tile.

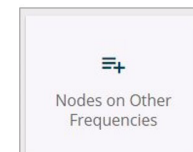

Figure 10. Node On Other Frequency

Highlight the new node being added and select Move Node to Frequency (#).

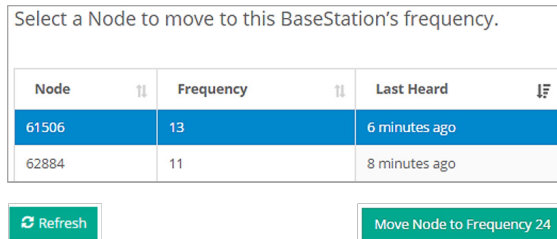

Figure 11. Move Node

C. Manually Add Node

Adding a node manually requires entering the node address and its current frequency setting.

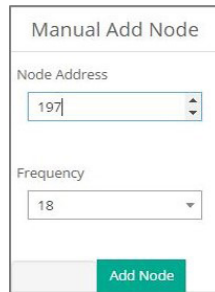

Figure 12. Add Node By Address

If the node was successfully added, two confirmation messages appear and it will be listed under the Base Station.

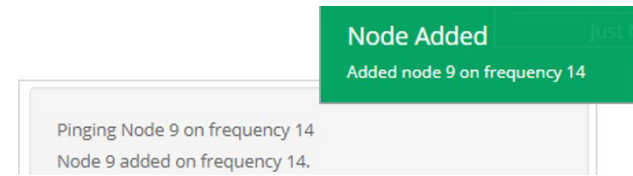

Figure 13. Add Node Confirmation

If the node fails to add, a failure message appears. The node did not respond to the base station which could indicate the node is not in idle mode or may be on another frequency. If “Add Node Anyway” is selected, it associates that node with the channel entered, but likely causes a communication error. If the node was not in idle, move the base station to the frequency of the node and issue a “Set to Idle” command.

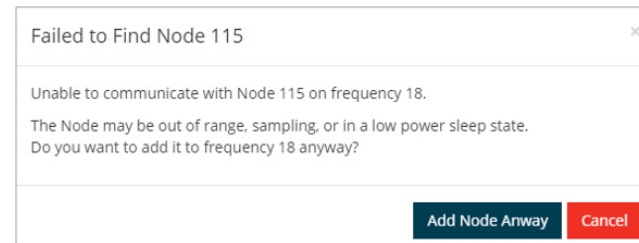

Figure 14. Failure to Add Node

7. Configure Node

Node settings are stored to non-volatile memory and are configured using SensorConnect. Select the Node under the Devices menu. Click on the Configure button under the Setup heading.

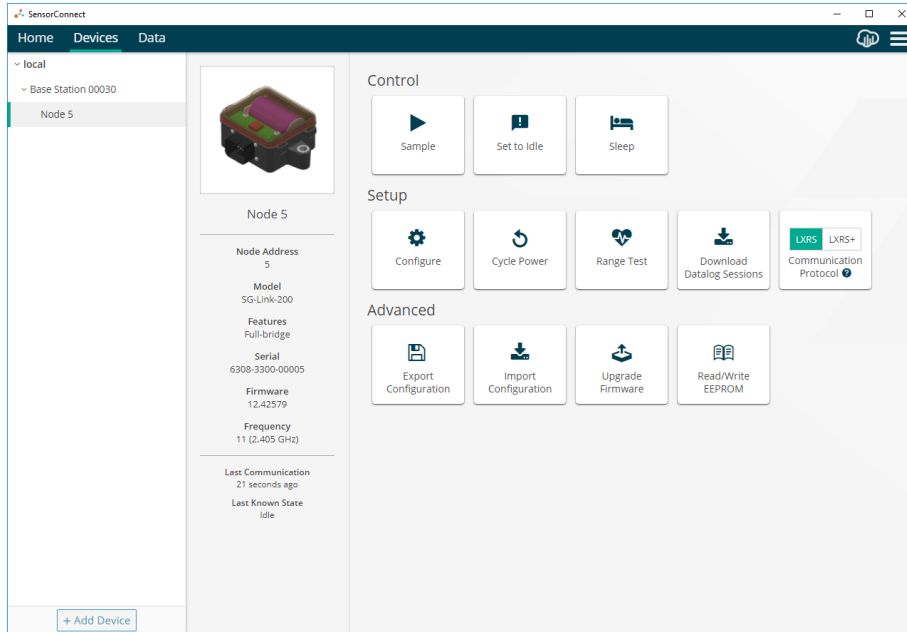

Figure 15. Node Configuration Menu

The Hardware menu tab displays the current node settings.

1. To change the default Input range settings, use the dropdown menus found under Input Range. This setting is used only when the Sensor Type is set to Uncompensated Resistance.
2. To change the default Low Pass Filter settings, use the dropdown menu found under Filter Cutoff.
3. Select Apply Configuration to write to node memory.

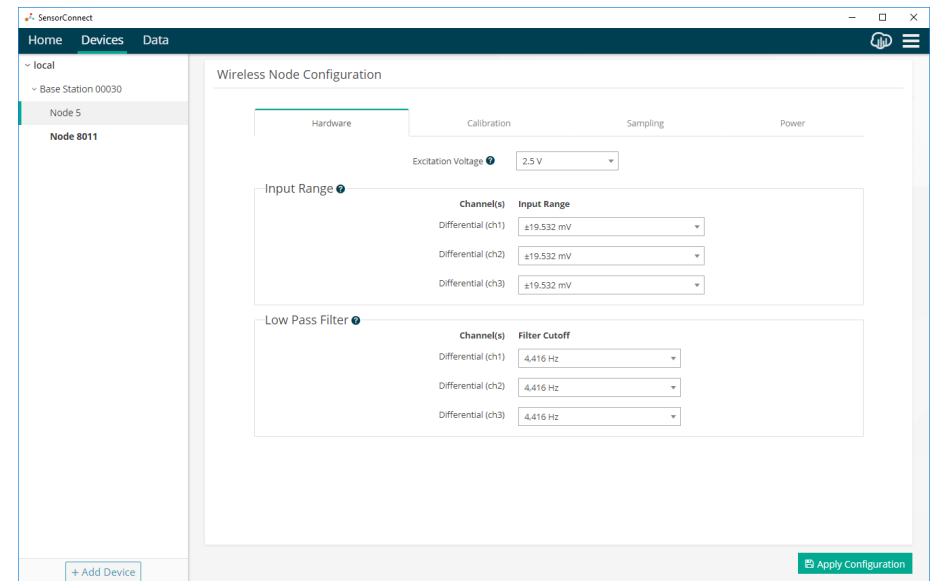

Figure 16. Hardware Configuration Tab

8. Configure Sampling Setting and Start Data Acquisition

1. Click the Base Station > Sample Network tile, and indicate the nodes to be sampled by checking the box to the left of each node in the list.

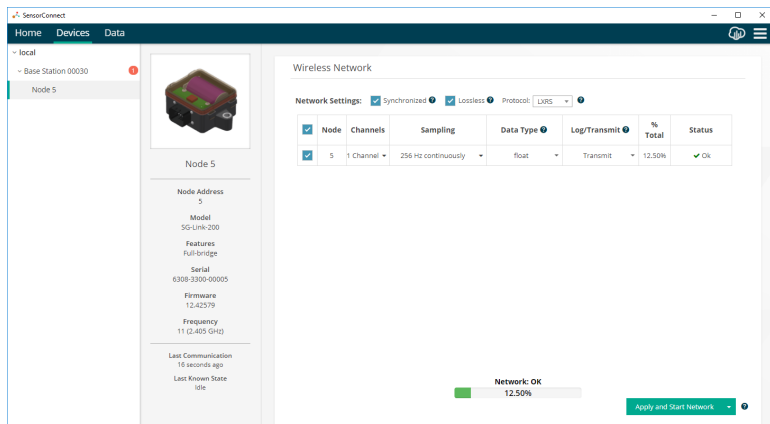

Figure 17. Select Node To be Sampled

2. Under the Sampling column, select Sample Rate from the drop down menu. Select Continuously to sample indefinitely.

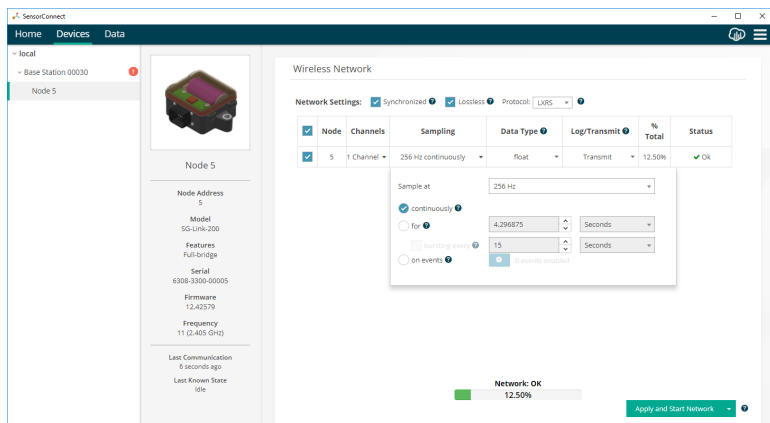

Figure 18. Sampling Setting

3. Select Apply and Start Network. A message indicates the Network Started and includes a shortcut link to the Data Tab.

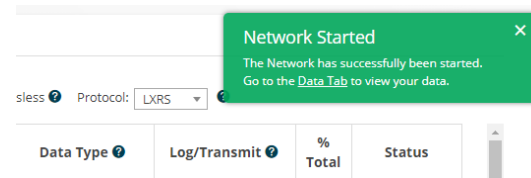

Figure 19. Network Started with shortcut to Data Tab

4. Navigate to the Data tab and view the Empty Dashboard 1. Click the +Add Widget button to add a Widget to Dashboard 1.

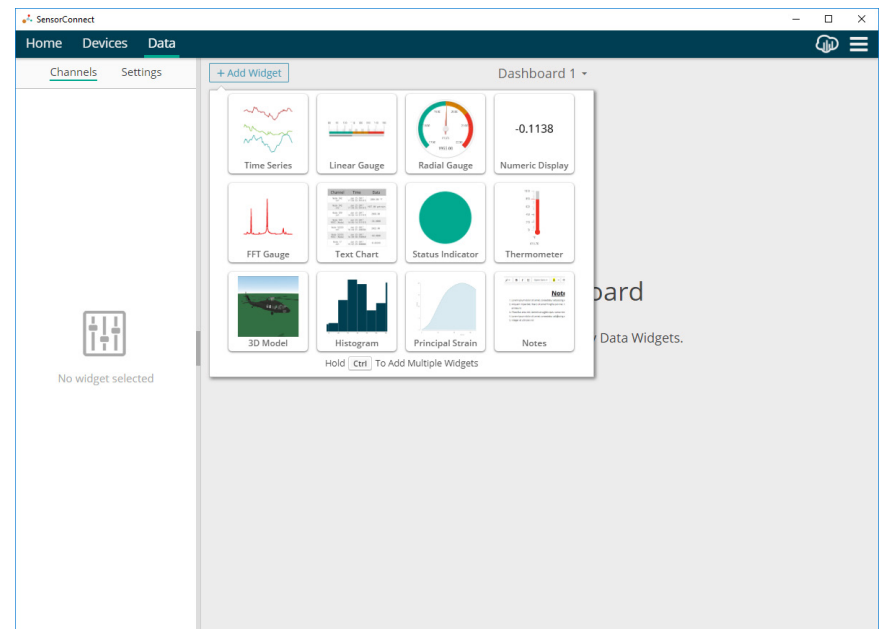

Figure 20. +Add Widget

- Select the Time Series tile to add a Time Series graph to Dashboard 1. The Time Series Graph displays with “No channels selected”. View the available channels and options under the Node’s **V** Menu.

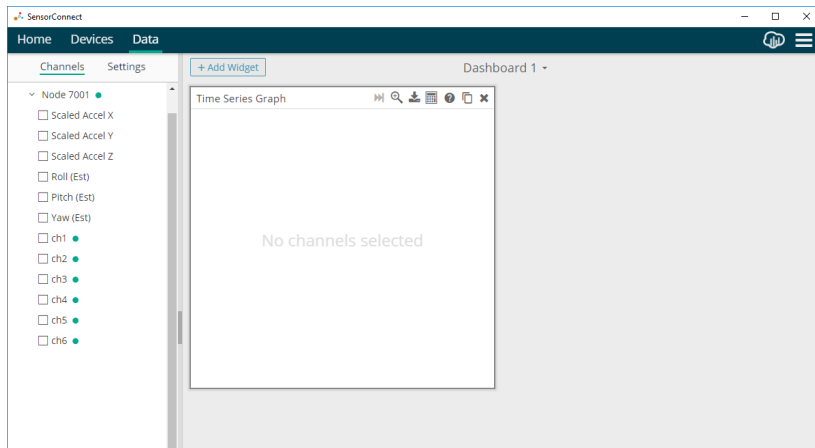

Figure 21. Add Time Series Graph Channel Selection

- Select the desired channels and options to begin data collection.

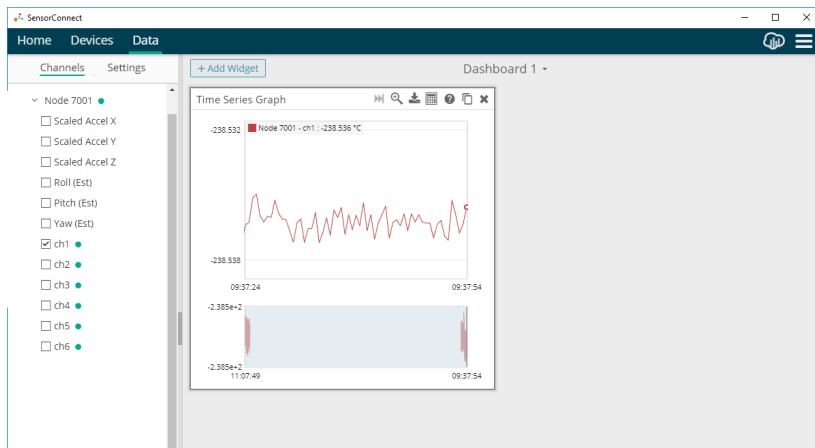

Figure 22. Time Series Graph with Channel 1 Selected

9. Radio Specifications

The SG-Link-200 employs a 2.4GHz IEEE 802.15.4 compliant radio transceiver for wireless communication. The radio is a direct-sequence spread spectrum radio and can be configured to operate on 16 separate frequencies ranging from 2.405 GHz to 2.480 GHz. Following the 802.15.4 standard, these frequencies are aliased as channels 11 through 26. For all newly manufactured nodes, the default setting is 2.425 GHz (channel 15).

SG-Link®-200

FCC ID: XJQMSLINK0011

IC ID: 8505A-MSLINK00 11

This device complies with Part 15 of the United States FCC Rules, and Industry Canada’s license-exempt RSSs. Operation is subject to the following two conditions: 1) This device may not cause interference, and

2) This device must accept any interference, including interference that may cause undesired operation of the device. Changes or modifications, including antenna changes not expressly approved by LORD Corporation could void the user’s authority to operate the equipment.

Cet appareil est conforme à la Partie 15 des Règles de la FCC des États-Unis et aux RSSS exempts de licence d’Industrie Canada. Le fonctionnement est soumis aux deux conditions suivantes: 1) Cet appareil ne doit pas causer d’interférences et 2) Cet appareil doit accepter toute interférence, y compris les interférences pouvant entraîner un fonctionnement indésirable de l’appareil. Les changements ou modifications, y compris les changements d’antenne non expressément approuvés par LORD Corporation, pourraient annuler l’autorisation de l’utilisateur d’utiliser l’équipement.

10. Battery Hazards



The SG-Link-200 contains internal, non-rechargeable lithium batteries. Lithium batteries are a fire and explosion hazard. Do not store or operate the node at temperatures above 212°F (100°C). Do not disassemble, short circuit, crush, puncture, or otherwise misuse the battery.

Lithium batteries contain toxic chemicals that are harmful to humans and the environment. Disposal is subject to federal and local laws. Do not discard the battery or the node in the trash. Follow proper battery disposal protocol, or contact LORD Sensing Technical Support for information on extracting the battery or returning the product for proper recycling and disposal.

11. Power Supply



Apply only the input voltage range specified for the SG-Link-200. Connect to a power source that is near the device, is accessible, and adheres to all national wiring standards. Compliance with wiring standards is assumed in the installation of the power source and includes protection against excessive currents, short circuits, and ground faults. Failure to do so could result in personal injury and permanent damage to the device.