

Enclosure Kit

SG-Link[®]-200-OEM
TC-Link[®]-200-OEM



Enclosure Kit for the SG-Link[®]-200-OEM and TC-Link[®]-200-OEM

LORD Sensing Wireless Sensor Networks enable simultaneous, high-speed sensing and data aggregation from scalable sensor networks. Our wireless sensing systems are ideal for test and measurement, remote monitoring, system performance analysis, and embedded applications.

The SG-Link-200-OEM[®] allows users to remotely collect data from a range of sensor types, including strain gauges, pressure transducers, and accelerometers. The node supports high resolution, low noise data collection from 3 differential input channels at sample rates up to 1 kHz.

The TC-Link-200-OEM[®] allows users to collect data from a range of sensor types including Thermocouples, Resistance Thermometers, and Thermistors. The node supports high resolution, low noise data collection from 1 temperature transducer at sample rates up to 128 Hz.

Users can easily program nodes for continuous, periodic burst, or event-triggered sampling with the SensorConnect software. The optional web-based SensorCloud interface optimizes data aggregation, analysis, presentation, and alerts for sensor data from remote networks.

PRODUCT HIGHLIGHTS

- Easy installation
- Low power consumption for extended use
- Uses 1 AA battery (3.6 V standard)

FEATURES AND BENEFITS

HIGH PERFORMANCE

- Lossless and time synchronized data collection
- Scalable network architecture
- Miniaturized packaging
- SensorConnect and SensorCloud software

APPLICATIONS

- Strain, load, force, pressure, temperature, acceleration, vibration, displacement, torque sensing
- Condition-based monitoring
- Structural load and stress monitoring
- Test and measurement
- RPM and Pulse counting
- Strain gauge rosettes
- Off-highway machine monitoring

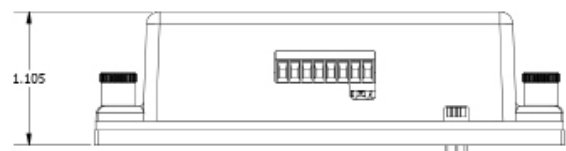
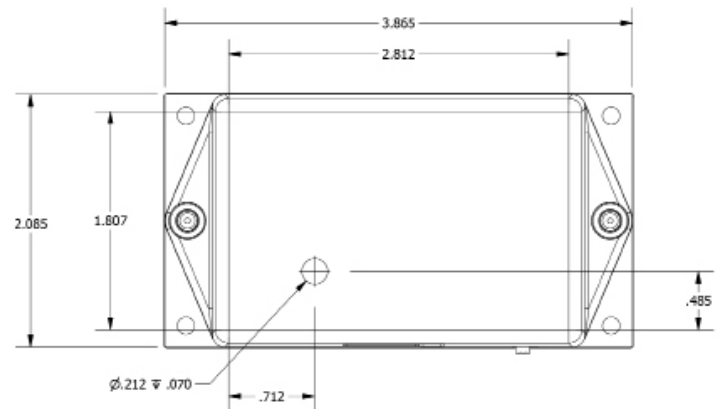

Enclosure Kit SG-Link®-200-OEM and TC-Link®-200-OEM

SG-Link®-200-OEM Wireless Analog Input Node



PRODUCT HIGHLIGHTS

- 1 differential and 1 single-ended input channel
- Differential channel compatible with 120, 350, and 1k Ohm Wheatstone bridge sensing circuits
- On-board temperature sensor
- Digital input channel for RPM and pulse counting
- Supply power from 3.3 to 30 V
- Continuous, periodic burst, and event-triggered sampling
- Output raw data and/or derived channels such as mean, RMS and peak-peak
- LXRS protocol allows lossless data collection, scalable networks and node synchronization of $\pm 50 \mu s$
- Remote strain calibration using on-board shunt resistor

HIGH PERFORMANCE

- Up to 1024 Hz sampling
- Low noise 1.5 or 2.5 V sensor excitation
- Noise as low as 1 μV p-p
- High resolution 24-bit data
- Datalog up to 8 million data points
- Low power operation, well-suited for battery powered applications.
- Wireless range up to 1 km (400 m typical)
- -40 to +105°C operating temperature range

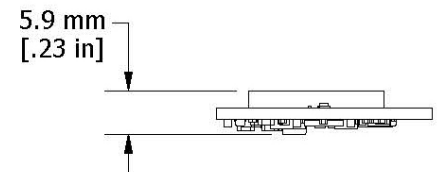
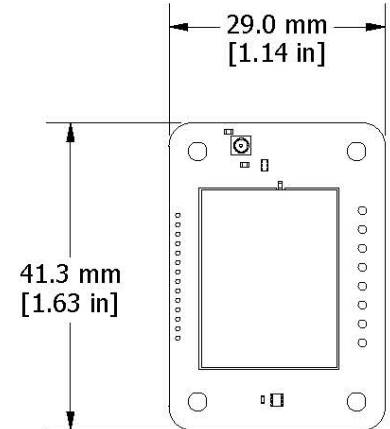

TC-Link®-200-OEM Wireless Temperature Sensor Node



PRODUCT HIGHLIGHTS

- 1 input channel supporting Thermocouples, Resistance Thermometers and Thermistors
- On-board linearization algorithms supporting a wide range of temperature transducers
- Small form factor, low power consumption and wireless
- Supply power from 3.3 to 30 V
- Continuous, periodic burst, and event-triggered sampling
- LXRS protocol allows lossless data collection, scalable networks and node synchronization of $\pm 50 \mu s$

HIGH PERFORMANCE

- Up to 128 Hz sampling
- High resolution 24-bit data
- Digital filtering for up to 120 db rejection of 50 and 60 Hz noise
- Datalog up to 8 million data points
- Duty Cycle sensor excitation for low power operation, well-suited for battery powered applications
- Wireless range up to 1km (400 m)

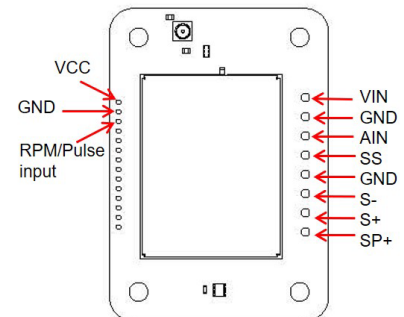

LORD Sensing MicroStrain
459 Hurricane Lane Suite 102
Williston, VT 05495 • USA
www.microstrain.com

Customer Support Center (in United States & Canada)
Tel: +1.802.862.6629
Email: sensing_support@LORD.com
For a listing of our worldwide locations, visit LORD.com

LORD SENSING
MicroStrain